

Article Info

Received: 30 Sept 2014 | Revised Submission: 25 Oct 2014 | Accepted: 20 Nov 2014 | Available Online: 15 Dec 2014

Mathematical Study of Reliability and MTTF of Industry under Common Cause Failure

Kavita Soni, U. R. Singh** and Rajeev Jha****

ABSTRACT

In this present paper is deal with a mathematical study of reliability and MTTF of an industry under common cause failure system. a system which consists of four subsystems, A, B, D and E connected in series. Subsystem A and B have two units in series, failure of either of the two causes complete failure of the system. Subsystem D has only one unit in series with B1 and B2. Subsystem E, the heat exchanger has two units connected in parallel redundance. Failure occurs only when both the units fail. By using supplementary variable technique, Laplace Transforms of the probabilities, being in various states, as well as up and down states of the system have been obtained along with steady state behavior and MTTF of the system. MTTF has also been discussed graphically.

Keywords: *MTTF, Reliability; Availability; Common Cause Failure System.*

1.0 Introduction

In modern industries system are designed to be operative for a specified period, i.e. there should be no failure in any equipment or part of equipment under specified operating conditions during the total period. Behavior analysis of each item of equipment under given operating conditions is helpful to design the component for minimum failure and to prepare a plan in advance for scheduled maintenance or preventive maintenance [1, 2].

In the urea fertilizer industry there are many process e.g. synthesis, decomposition, crystallization and recovery.

Singh, J, et. Al, [3] did a lot of work related to the functionary part of the fertilizer plant, Kumar et, al [4] discussed about the decomposition process in the urea plant and obtained availability of the system under general repair policy. Ignoring the idea of standby redundancy used by [4] in heat exchanger, Gupta and Singhal [5] have studied on Cost analysis of a multi component parallel redundant complex system with over lording effect and waiting under critical human error, Giyshu and Gayal [6] have discussed on a two- dissimilar unit multi component system with correlated failure and repairs. Batra [7] has worked on Pointwise Availability of a standby redundant complex system incorporating human failure. Agnihotri et. al. [8] on studied on Reliability

analysis of a system of boiler used in readymade garment industry. El-Damcese and Ayoub [9] have discussed on Reliability equivalence factors of a Parallel system in two-dimensional Distribution. Recently Manglik and Mangey [10] have studied on Reliability analysis of a two unit cold Standby system using markov process.

Earlier workers also ignored the important concept of common cause failure. A large percentage of failure in system occurs due common cause failure. Common cause failure is defined as any instance where multiple units or components fail due to single cause. A common cause failure may occur due to vibrations, temperature, fire, flood, operational and maintenance error, design, deficiency etc.

Keeping above facts in mind, in this chapter we considered a system which consists of four subsystems, A, B, D and E connected in series.

- (a) Subsystem A has two units A1 and A2, failure of either of the two causes complete failure of the system. Unit A1 is called the reboiler for high pressure absorber and A2 is called is falling fill-in heater for the low pressure absorber.
- (b) Substance B has two units B1 and B2 in series unit B1 is called the high pressure absorber and B2 is called the low pressure absorber.
- (c) Subsystem D has only one unit called the gas separation. It is connected in series with B1 and B2.

*Corresponding author; Department of Mathematics, C. L. (P.G.) Jain College, Firozabad, Uttar Pradesh, India (E-mail: ajaykumarsharma1982@gmail.com)

**Department of Mathematics, C. L. (P.G.) Jain College, Firozabad, Uttar Pradesh, India

***Department of Mathematics, Teerthanker Mahaveer University, Moradabad, Uttar Pradesh, India

(d) Subsystem E, the heat exchanger has two units connected in parallel redundancies. Failure occurs only when both the units fail.

By using supplementary variable technique, Laplace Transforms of the probabilities, being in various states, as well as up and down states of the system have been obtained along with steady state behavior and MTTF of the system. MTTF has also been sketched. The state transition diagram of the system is shown in fig. 1.

2.0 Assumptions

- (i) Failure rate of each sub-system is constant
- (ii) Repair facility is always available
- (iii) Repair throughout is assumed to follow general time distribution.
- (iv) Both the units is sub system E are similar and connected in parallel redundancy.
- (v) System fails either due to its normal failure or due to common cause failure.
- (vi) Repaired sub system works like new

Fig 1: State Transition Diagram of the System

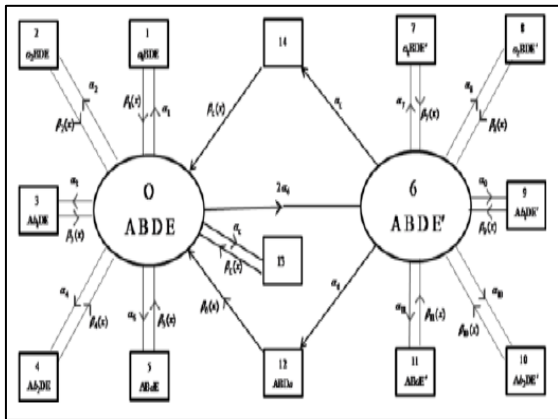

3.0 Formulation of Mathematical Model

Using elementary probability considerations and continuity arguments, the set of difference differential equations, which is discrete in space and continuous in time are as under:

$$\left[\frac{d}{dt} + \sum_{i=1}^6 \alpha_i + \alpha_6 + \alpha_c \right] P_0(t) = \sum_{i=1}^5 P_i(x,t) \beta_i(x) dx + \int P_{12}(x,t) \beta_6(x) dx + \sum_{j=13}^{14} \int P_j(x,t) \beta_c(x) dx$$

... (1)

$$\left[\frac{\partial}{\partial x} + \frac{\partial}{\partial t} + \beta_i(x) \right] P_i(x,t) = 0 \quad \text{for } i = 1, 2, \dots, 5 \quad (2)$$

$$\left[\frac{d}{dt} + \sum_{m=7}^{11} \alpha_m + \alpha_6 + \alpha_c \right] P_6(t) = 2\alpha_6 P_0(t) + \sum_{m=7}^{11} P_k(x,t) \beta_k(x) dx \quad (3)$$

$$\left[\frac{\partial}{\partial x} + \frac{\partial}{\partial t} + \beta_k(x) \right] P_k(x,t) = 0 \quad \text{for } k = 7, 8, \dots, 11 \quad (4)$$

$$\left[\frac{\partial}{\partial x} + \frac{\partial}{\partial t} + \beta_6(x) \right] P_{12}(x,t) = 0 \quad (5)$$

$$\left[\frac{\partial}{\partial x} + \frac{\partial}{\partial t} + \beta_c(x) \right] P_j(x,t) = 0 \quad \text{for } j = 13, 14 \quad (6)$$

3.1 Boundary Conditions

$$P_i(0,t) = \alpha_i P_0(t) \quad \text{for } i = 1, 2, \dots, 5. \quad (7)$$

$$P_k(0,t) = \alpha_k P_6(t) \quad \text{for } k = 7, 8, \dots, 11. \quad (8)$$

$$P_{12}(0,t) = \alpha_6 P_6(t) \quad (9)$$

$$P_{13}(0,t) = \alpha_c P_0(t) \quad (10)$$

$$P_{14}(0,t) = \alpha_c P_0(t) \quad (11)$$

3.2 Initial condition

$P_0 = 1$ and other state probabilities are zero at $t = 0$. (12)

3.3 Solution of the Model

Taking Laplace transform of the equations (1) through (11) using equation (12), we get

$$\left[s + \sum_{i=1}^6 \alpha_i + \alpha_6 + \alpha_c \right] P_0^*(s) = 1 + \sum_{i=1}^5 \int P_i^*(x,s) \beta_i(x) dx + \int P_{12}^*(x,s) \beta_6(x) dx + \sum_{j=13}^{14} \int P_j^*(x,s) \beta_c(x) dx \quad (13)$$

$$\left[\frac{\partial}{\partial x} + s + \beta_i(x) \right] P_i^*(x,s) = 0 \quad \text{for } i = 1, 2, \dots, 5 \quad (14)$$

$$\left[s + \sum_{m=7}^{11} \alpha_m + \alpha_6 + \alpha_c \right] P_6^*(s) = 2\alpha_6 P_0^*(s) + \sum_{m=7}^{11} \int P_k^*(x,s) \beta_k(x) dx \quad (15)$$

$$\left[\frac{\partial}{\partial x} + s + \beta_k(x) \right] P_k^*(x,s) = 0 \quad \text{for } k = 7, 8, \dots, 11 \quad (16)$$

$$\left[\frac{\partial}{\partial x} + s + \beta_6(x) \right] P_{12}^*(x,s) = 0 \quad (17)$$

$$\left[\frac{\partial}{\partial x} + s + \beta_c(x) \right] P_j^*(x,s) = 0 \quad \text{for } j = 13, 14 \quad (18)$$

$$P_i^*(0,s) = \alpha_i P_0^*(s) \quad \text{for } i = 1, 2, \dots, 5. \quad (19)$$

$$P_k^*(0,s) = \alpha_k P_6^*(s) \quad \text{for } k = 7, 8, \dots, 11. \quad (20)$$

$$P_{12}^*(0, s) = \alpha_6 P_6^*(s) \quad \dots (21)$$

$$P_{13}^*(0, s) = \alpha_c P_0^*(s) \quad \dots (22)$$

$$P_{14}^*(0, s) = \alpha_c P_0^*(s) \quad \dots (23)$$

In view of equation (19) to (23), we get the following results from (14), (16), (17) and (18).

$$P_i^*(0, s) = \alpha_i P_0^*(s) \left[-sx - \int_0^x \beta_i(x) dx \right] \text{ for } i=1,2,\dots,5 \dots (24)$$

$$P_k^*(0, s) = \alpha_k P_0^*(s) \left[-sx - \int_0^x \beta_k(x) dx \right] \text{ for } k=7, 8,\dots,11 \dots (25)$$

$$P_{12}^*(0, s) = \alpha_6 P_6^*(s) \left[-sx - \int_0^x \beta_6(x) dx \right] \quad \dots (26)$$

$$P_{13}^*(0, s) = \alpha_c P_0^*(s) \left[-sx - \int_0^x \beta_c(x) dx \right] \quad \dots (27)$$

$$P_{14}^*(0, s) = \alpha_c P_0^*(s) \left[-sx - \int_0^x \beta_c(x) dx \right] \quad \dots (28)$$

On minor simplification, we get the following Laplace transform of varies state probabilities

$$P_0^*(s) = \frac{1}{D(s)} \quad \dots (29)$$

$$P_i^*(s) = \alpha_i R_i(s) \frac{1}{D(s)} \text{ for } i=1,2,\dots,5 \quad \dots (30)$$

$$P_6^*(s) = \frac{2\alpha_6}{C(s)} \cdot \frac{1}{D(s)} \quad \dots (31)$$

$$P_k^*(s) = \frac{\alpha_k \cdot 2\alpha_6 R_k(s)}{C(s)} \cdot \frac{1}{D(s)} \text{ for } k=7,8,\dots,11 \quad \dots (32)$$

$$P_{12}^*(s) = \frac{2\alpha_6^2 R_6(s)}{C(s)} \cdot \frac{1}{D(s)} \quad \dots (33)$$

$$P_{13}^*(s) = \alpha_c R_c(s) \cdot \frac{1}{D(s)} \quad \dots (34)$$

$$P_{14}^*(s) = \frac{\alpha_c \cdot 2\alpha_c R_c(s)}{C(s)} \cdot \frac{1}{D(s)} \quad \dots (35)$$

Where

$$A(s) = x + \sum_{i=1}^6 \alpha_i + \alpha_6 + \alpha_c - \sum_{i=1}^5 \alpha_i s_i^* - \alpha_c s_c^*(s)$$

$$B(s) = \alpha_6 s_c^*(s) + \alpha_c s_c^*(s)$$

$$C(s) = s + \sum_{m=7}^{11} \alpha_m + \alpha_6 + \alpha_c - \sum_{m=7}^{11} \alpha_m \bar{s}_m(s)$$

$$D(s) = \frac{A(s)C(s) - B(s)2\alpha_6}{C(s)}$$

$$R_i(s) = \frac{1 - s_i^*(s)}{s}$$

Laplace transform of the probability that at time t, system is in upstate is given by

$$P_{up}^*(s) = \frac{2\alpha_6 + C(s)}{C(s)} \cdot \frac{1}{D(s)} \quad \dots (36)$$

Also Laplace transform of the probability, that at time t, system is in down state i.e. in failed state is given by

$$P_{down}^*(s) = \left[\sum_{i=1}^5 \alpha_i R_i(s) + \frac{2\alpha_6}{C(s)} \left(\alpha_6 R_i(s) + \sum_{i=1}^5 \alpha_i R_k(s) \right) \right.$$

$$\left. + \left(1 + \frac{2\alpha_6}{C(s)} \right) R_c(s) \right] \cdot \frac{1}{D(s)}$$

(37)

It is worth noticing that

$$P_{up}^*(s) + P_{down}^*(s) = \frac{1}{s} \quad \dots (38)$$

Steady State Probabilities:

Using Abel's Lemma

$$\lim_{t \rightarrow 0} P_i(t) = \lim_{s \rightarrow 0} s P_i^* = P_i(\text{say}), \text{ we}$$

many obtain the following state probabilities which are independent of time:

$$P_0 = \frac{1}{D'(0)} \quad \dots (39)$$

$$P_i = \alpha_i M_i \cdot \frac{1}{D'(0)} \text{ for } i=1,2,\dots,5 \quad \dots (40)$$

$$P_6 = \frac{2\alpha_6}{C(0)} \cdot \frac{1}{D'(0)} \quad \dots (41)$$

$$P_k = \frac{\alpha_k \cdot 2\alpha_6 M_k}{C(0)} \cdot \frac{1}{D'(0)} \text{ for } k=7,8,\dots,11 \quad \dots (42)$$

$$P_{12} = \frac{2\alpha_6^2 M_6}{C(0)} \cdot \frac{1}{D'(0)} \quad \dots (43)$$

$$P_{13} = \alpha_c M_c \cdot \frac{1}{D'(0)} \quad \dots (44)$$

$$P_{14} = \frac{\alpha_c \cdot 2\alpha_6 M_c}{C(0)} \cdot \frac{1}{D'(0)} \quad \dots (45)$$

The long run availability of the system is then given by

$$P_{up} = \frac{2\alpha_6 + C(0)}{C(0)} \cdot \frac{1}{D'(0)} \quad \dots (46)$$

Also, the steady stste probability of the down state of the system is given by

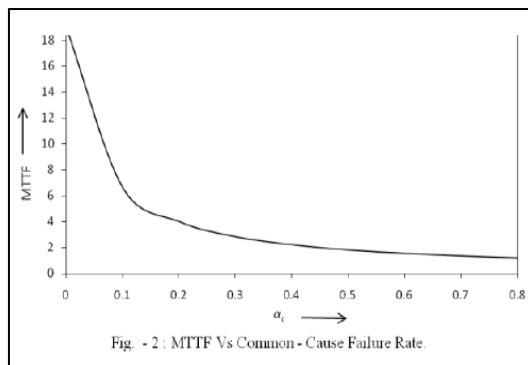

References

[1] J. A. Abraham, An improved Algorithm for Network Reliability, IEEE Trans. on Rel., (1979, 28

[2] P. R. Parthasarthy, Cost analysis for two unit systems; IEEE Trans. On Rel., 28, 1979, 268 – 269

[3] J. Singh, P. C. Pandey, D. Kumar, Designing for reliable operation of Urea Synthesis In fertilizer Industry, Microelectron, Rel., 30, 1990, 1021 – 1024

[4] D. Kumar, P. C. Pandey, J. Singh, Behavior analysis of urea fertilizers understand by redundancy process, 1991

[5] P. P. Gupta, A. Singhal, Cost analysis of a multi component parallel redundant complex system with over loding effect and waiting under critreal human error, Microelectron Rel., 31, 1991, 865-868

[6] R. Giyshu. S. Z. Muuitaj, R. Gayal, A Two-dissimilar unit multi component system with correlated failure and repairs, Microelectron, reliability, 37(S), 1997, 845-849

[7] C. M. Batra, Pointwise Availability of a standby redundant complex system incorporating human failure, Bulletin of pure and applied sciences, 19f (1), 2000, 205-215

[8] R. K. Agnihotri, Khare, Ajit and Jain, Sanjay., Reliability analysis of a system of boiler used in Readymade garment industry, Journal of

Reliability and Statistical Studies, 1(1), 2008, 33-41

[9] M. A. El-Damcese, D. S. Ayoub, Reliability equivalence factors of a Parallel system in two-dimensional Distribution, Journal of Reliability and Statistical Studies, 4(2), 2011, 33-42

[10] Manglik, Monika, Ram, Mangey, Reliability analysis of a two unit cold Standby system using markov process, Journal of Reliability and Statistical Studies, 6(2), 2013, 65-80

Notations

- A, B, D, E Denotes the operable state of the sub system.
- a, b, d, e Denotes the failed state of the sub system.
- Ei denotes the state of sub system E when its one unit has failed.
- O Operable state, when both the units in sub section E are good.
- s Operable state when one unit in sub system E has failed.
- ai Failure rate of the units A1, A2, B1, B2, D and E (i = 1, 2, 3, 4, 5, 6).
- aj Failure rates of the unit E, A1, A2, B1, B2 and D, when only one unit of E is in operation (j = 6,11).
- ac Common cause failure rate of the system when it is either in state 0 or 6.
- $\beta_i(x)$ General repair rates of the units a1, a2, b1, b2 and d (i = 1, 2,5).
- $\beta_j(x)$ General repair rates of the units e, a1, a2, b1, b2 and when only one unit of E is in operative state (i = 6, 7,11).
- $\beta_c(x)$ Denote the general repair rate of the system in failed state (failed due to common cause failure).
- Pi (t) Probability, that at time t, the system in state i.
- Pi (x, t) pdf (system is in state i at time t and is under repair, elapsed repair time x).
- Mi Mean time of repair.